

PETER GH SEBALD



BMW M3 E30, 1986 - 1991
17.970 – EMOTIONS



TABLE OF CONTENTS:

• FOREWORD BY MARC HESSEL	1
• THE ORIGINAL IDEA BACK IN 1983	3
• A VISION BECOMES REALITY	5
• THE PHILOSOPHY OF BMW MOTORSPORT GMBH	7
• DEVELOPMENT BASED ON THE E30	15
TESTING IN THE “GREEN HELL” (NÜRBURGRING, GRÜNE HÖLLE)	17
NOT JUST “BEATING PANEL	20
• 1985: THE FRANKFURT MOTOR SHOW	23
• 1986: MUGELLO, ITALY	29
A BRAND-NEW STRATEGY: MARKETING AND SALES OF THE MIRACLE CAR	
• SEPTEMBER 1986: THE FIRST CARS HIT THE ROAD	34
• 1987: THE EVO ENGINE AND FROM THE START WORLD CHAMPION	45
• AN AMERICAN FRIEND	55
• 1988: THE EVOLUTION	62
THE FIRST-EVER M3 CONVERTIBLE	
ONLY TOUGH GUYS GO TO HEAVEN (THE EDC)	
• THE M3 “EUROPEAN CHAMPION”: AN HOMAGE TO ROBERTO RAVAGLIA	82
• EXTRA POWER STRAIGHT FROM THE FACTORY	85
• 1989: ENGINE OUTPUT WITH CATALYST NOW 215 BHP	88
• M3 “CECOTTO”: AN HOMAGE TO JOHNNY CECOTTO	94
• 1990: THE SPORT EVOLUTION	100
• SPECIAL MODELS BUILT FOR SPECIAL PURPOSES – RIGHT-HAND DRIVE	115
• END OF PRODUCTION, WEIGHTS, EXPORTS, PRICELIST	117
• HEAVY METAL, THE PLAQUES	125
• COMPETITORS AND COMPETITION	129
• ALPINA	133
• HARTGE	153
• BAUR	157
• THE TUNERS: AC SCHNITZER, HAMANN MOTORSPORT, LOTEC, MK	171
• THE ART CARS	189
• CREATIONS: SACRILEGE OR BOLD ACHIEVEMENT? THE M3 PICK UP	195
KOENIG SPECIALS, MATTHES, MANHART	
GREAT PRIVATE COLLECTOR CARS	
SMALL COLLECTOR’S ITEMS: AUTOART, MINICHAMPS	
BEAUTIFUL ENGINES – THE HEART OF THE M3, AIRBOX, BILSTEIN AND YOKOHAMA	
• BMW MOTORSPORT GMBH	223
• THE GROUP A CAR	231
• THE “M”OTOR AND THE REGULATIONS	243
• GROUP N	256
• THE GROUP A IN RALLY TRIM	259
• BMW M TEAM	276
• BMW M TEAM SCHNITZER – THE THREE KINGS	282
• BMW M TEAM LINDER	305
• BMW M TEAM BIGAZZI	311
• BMW M TEAM ZAKSPEED	323
• THE BMW M3’S STORY OF SUCCESS IN MOTORSPORT	331
MOST IMPORTANT RACES AND VICTORIES BETWEEN 1987 AND 1993	
1987 TO 2007: HE WILL NEVER DIE	
• MY STORY, MARC HESSEL FT. M3 E30 FT.M3 E92, 20 YEARS DIFFERENT	442
• ACKNOWLEDGMENTS	

1983: A VISION BECOMES REALITY

Thinking of Munich, many people first think of the *Hofbräuhaus*. But there is another building in the north of Munich which fascinates the aficionado of great cars, enthusiasts of sporting performance and true visionaries a lot more: the BMW Four-Cylinder Building on Petuelring. And that is precisely where a vision was born in 1983.

BMW had of course already set the standard in motorsport in the past, starting with the BMW 328, moving on to the 1800 TISA, the legendary 02, the beautiful 3.0 CSL, the wild Group 5 320, the 528 and all the way to the 635 CSi. But by 1983 the 6 Series had passed its climax and the time had come to develop a project with a great future.

In February 1983 the brains, development specialists and visionaries at Motorsport GmbH got together, started thinking hard, and developed the concept of a new racing car. And they very quickly agreed on the main features and highlights the car had to have. It was to be a racing car from Bavaria once again setting standards the world over.

The ultimate Group A car ideal for outstanding success not only in motorsport, but also on the road. And, of course, a car full of emotion.

Eberhard von Kuehnheim, at the time the Chairman of the Board of BMW, had already been telling Paul Rosche ever since the mid-70s that BMW needed a compact sports saloon as a particularly outstanding model in the range.

Paul Rosche: "Mr von Kuehnheim came to see us and said in leaving that he would like to have a high-performance 3 Series. I found the idea really thrilling! Great, I said to myself..."

So what could have been more obvious in 1983 than to take the current 3 Series as the starting point for the M3 project?

The name of the car was to be clear, easy to remember and full of sportiness. It was to be made up of a letter and a number: M3. So now the myth had a name. And a unique thing in the history of the automobile was that the racing car came first as the foundation for developing a production model.

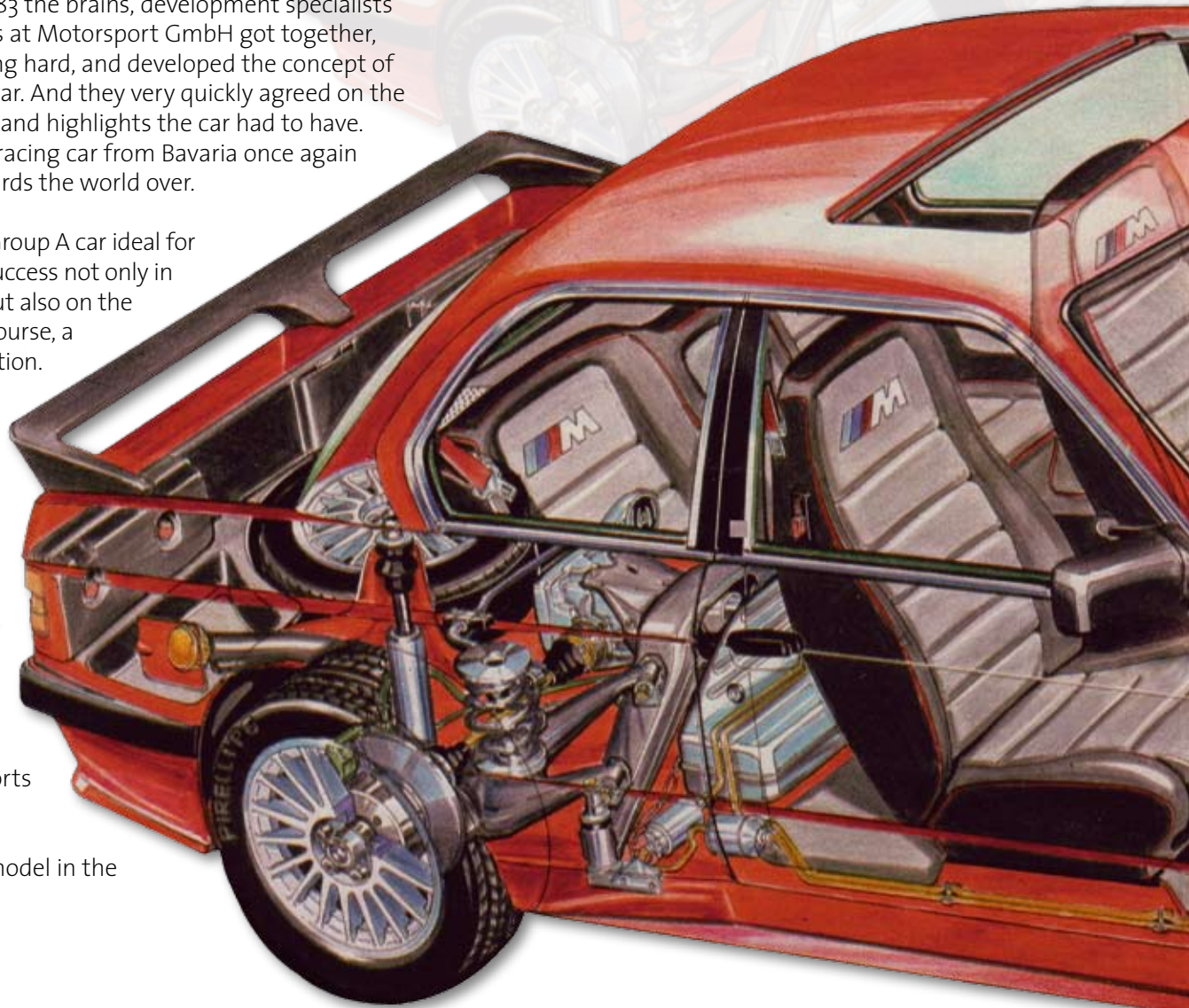

(The insiders working on their drawing boards knew from the start that the successor to the legendary 02 was to be an aggressive, extra-wide 3 Series... or was that just a dream? Be it as it may, the wide wheel arches were already reality.)

THE PHILOSOPHY OF MOTORSPORT GMBH

STRAIGHT FROM THE HEART

It was to be compact, featuring a four-cylinder power unit, the most successful engine concept already boosted by BMW in Formula One to 1000 bhp. Because BMW had always been very successful with four-cylinders.

BMW had been using an appropriate engine block ever since 1962. With power and performance in motor-sport coming from engine speed, six-cylinder engines reached their physical limits relatively soon due to torsional vibration on the crankshaft. By contrast, the four-cylinder, with its shorter and stiffer crankshaft, is far less sensitive to high engine speeds and offers a more suitable starting point for a high-performance power unit. And precisely that was an essential prerequisite for such a compact high-performance car. The engine was to be the heart of the M3!

COMING STRAIGHT DOWN FROM “HEAVEN”

The father of all M engines was and is Paul Rosche.

Paul Rosche: *“ZS is based at two locations. First, in Preussenstrasse, where we develop and build the engines. Second, in Garching just north of Munich, in Daimlerstrasse, where we build our M Cars. Gerhard Richter, my successor, is now responsible for engines and the car itself at ZS. And since, in the course of time, there were simply too many ZS products, the subsidiary was re-named “M”, which remains its name to this day.”*



(Paul Rosche)

It is however only fair to add that “Camshaft Paul” was not the only man developing the engine. For right at the beginning of the S14 engine generation all the way to the end of 1982, he was supported by a sensational newcomer to the company called Helmut Himmel (which just happens to mean “heaven” in English...) An ingenious, very young and likeable man straight from university taking over all kinds of tasks on the intake and injection system of the S14 power unit.

Helmut Himmel: *“Yes, I remember very well working on the intake system”* And so, even in young years, this newcomer to the scene set a milestone at Motorsport GmbH for one of the best four-valve power units the world has ever seen. And years later, when the author was conducting research on this M3 book, Helmut Himmel – would you believe it – had become the Project Manager for BMW’s M engines.



(Helmut Himmel)

M – S – Z – ZS – M

Helmut Himmel: *“M” was the abbreviation we used at BMW for all our engines. But since we wanted to be different, we opted for the abbreviation “S”. After all, back then we were still a subsidiary referred to within BMW as “ZS”. The abbreviation “Z” stands for “subsidiary” in BMW’s parlance. And “ZS” refers to everything we do in motorsport, everything that involves the “M” .”*

Measuring 37 mm in diameter, the intake valves were positioned at an angle of 18°, the exhaust valves (32 mm in diameter) at an angle of 20°. The four spark plugs were fitted right in the middle between the valves.

The four-cylinder was a compact and straightforward engine easy to understand and appreciate.

To minimise the vibration on the test models, a reinforcement component with a stiffening effect was fitted between the engine block and the gearbox housing, suppressing vibration and oscillation resonance.

Even so, the S14 power unit was much rougher than its production counterpart. To ensure good torque and sufficient starting-off engine speed also in cold weather, the starter developed 1.4 kW and came complete with a layshaft gear.

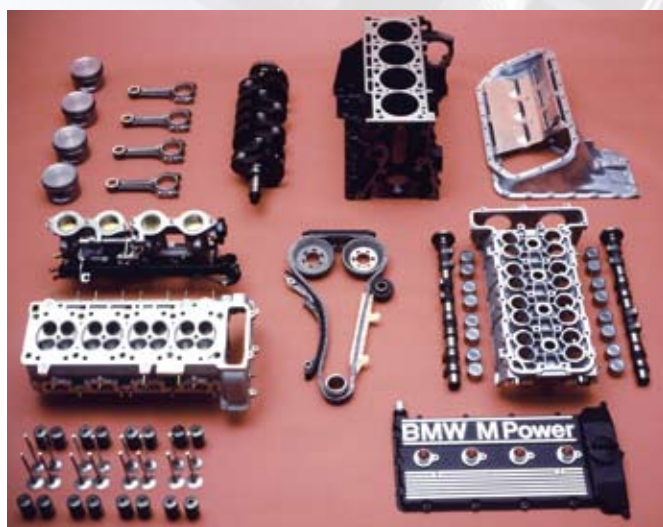
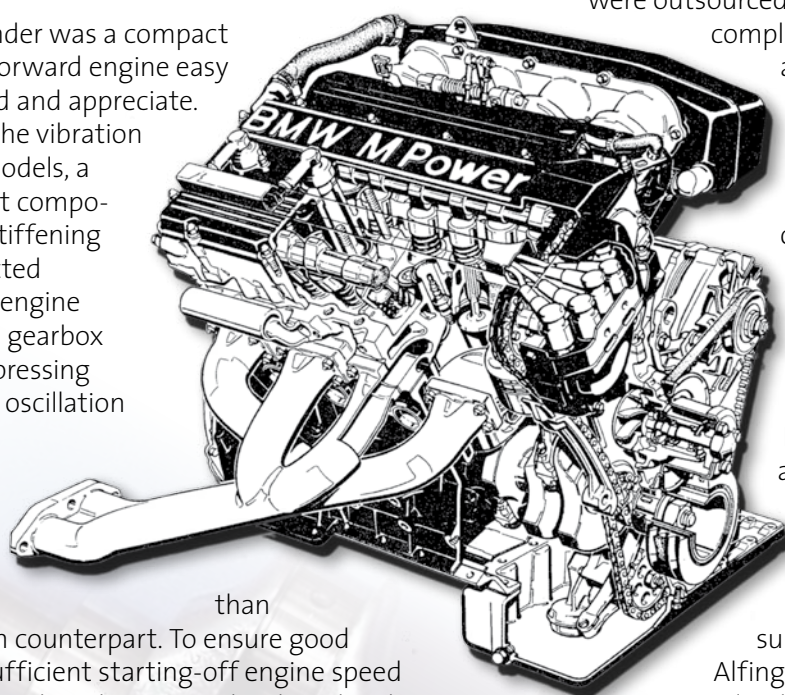

The particular forte of the S14 power unit was however not to be the proverbial smoothness and motoring refinement so typical of BMW's silken-smooth six-cylinders, but rather the high engine speeds so crucial to motorsport. Just consider that the speed limit in the Group A version was to be 10,000 rpm.

Many components and individual parts on the S14 power unit were made by BMW in-house. Still, a number of components were outsourced either

completely or at least in

the basic production process providing the crude parts for further machining by BMW. Like many other crankcases on the production engines in other model series, the crankcase on the S14 power unit was made of **HB 170 – 230 CAST PERLITE** and was supplied in its crude form by EWB Eisenwerke Brühl, with subsequent machining and fine-tuning by BMW.

The crankshaft made of **42CrMo4 Rm 880 – 1030 N/mm²** was supplied in its crude form by Gerlach, with subsequent precision-machining by Alfing. The flywheel was outsourced completely, being made and supplied by

Hay in **C45N** quality. The four connecting rods in **34CrNiMoV 11000 – 1200 N/mm²** came as crude components from Brockhaus and were then finished by engine specialists at BMW in the final machining process.

The pistons were also outsourced completely, coming in **GK-AlSi10CuMgNi** from Mahle, who also supplied the piston rings. The camshafts supplied to BMW in their crude form by Wizemann were one of the most important components on this fast-revving four-valve power unit and were made in **StU66** in a spherical graphite

hard-casting process. BMW's top specialists then took care of the final precision machining, particularly as the valve head was different on the two valves.

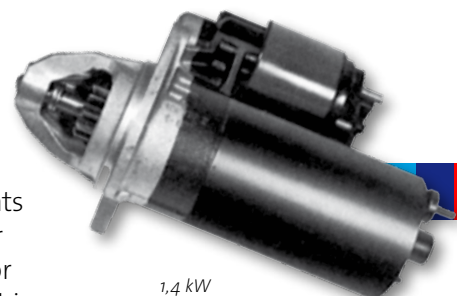

1.4 kW
Starter

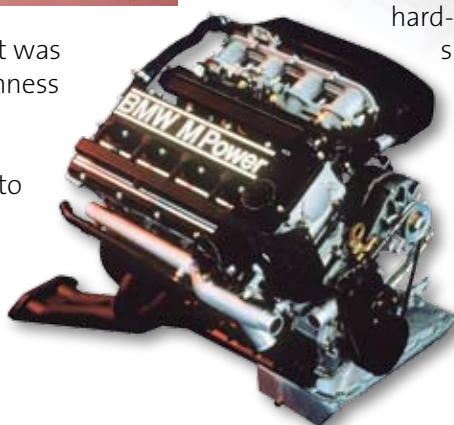

DEVELOPMENT BASED ON THE E30

In 1983 BMW was set to change over to the new 3 Series. And with the body of the car already fully developed and ready for production, the obvious decision was to take the “foundation” of the new 3 Series as the starting point for BMW’s new compact supersports.

It was really a coincidence and nothing but a coincidence that BMW developed the M3 and that incredible engine at the same time. Others claim this was BMW’s reaction to the Mercedes 190E 2.3-16 very successful back then. But that is definitely not true, since the initial idea to build a really fast and dynamic 3 Series went all the way back to the late ‘70s and early ‘80s. So the concept had already been in place for a long time.



Focusing on the M3, BMW’s “M” visionaries had very clear and concrete ideas about the performance of their baby. They wanted a car with wide wheel arches for racing wheels, with spoilers front and rear for good aerodynamics in

battling the wind at very high speeds, and a suspension able to offer the very best driving performance under all conditions and in all situations, as well as brakes worthy of a racing car.

Through its dimensions alone, the brake system offered the very best available at the time. Up front the M3 featured inner-vented brake discs measuring 280 mm in diameter and 25 mm across. At the rear the M3 came

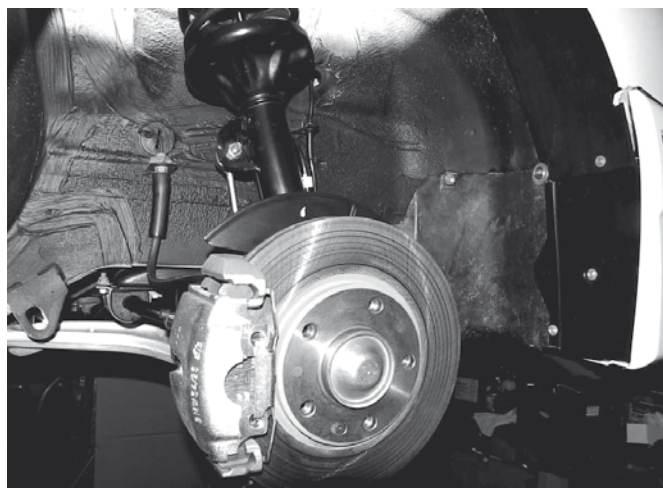

with 282-mm discs measuring 10 mm in thickness. The brake callipers were larger than usual, coming straight from the BMW 5 Series E28. The master brake cylinder measured 23.8 mm in diameter, ABS anti-lock brakes were featured as standard, and the pulse gear was new in design.

Gearshift configuration on the 265/5 sports gearbox was optimised to an even higher standard than before and the gearbox mounts were modified to fit the new model. The gearbox itself came from BMW M, and the intention was to clearly highlight the origin of the car inside on the gearshift lever and the gaiter finished in leather and with BMW M stripes. The propeller shaft was adjusted at the front to fit the modified gearbox and tube diameter was increased to 70 millimetres to take the higher revs into account. The pivot disc was also enlarged and reinforced in the same way as the centre bearing to meet the greater requirements made of the car.

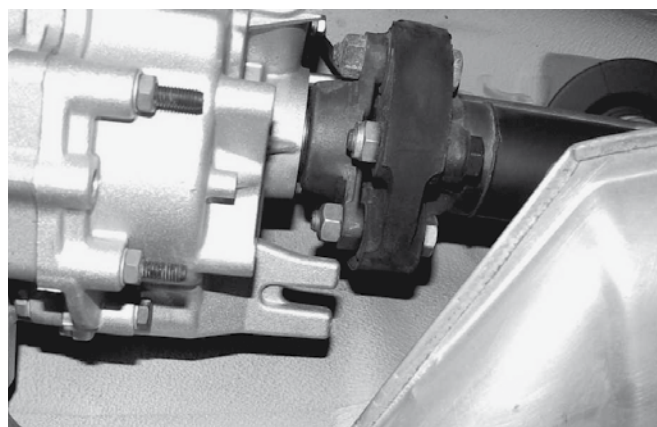

TESTING IN “GREEN HELL” (GRÜNE HÖLLE)

The new M3 was not just a particularly sporting version of the regular M3, but was rather intended to set the absolute benchmark in all Touring Car Championships. And where is the best place to test any car to the absolute extreme? It's on Nürburgring.

In terms of its chassis and suspension, the M3 was to stand out clearly from the most powerful 3 Series at the time, the 323i, while still offering acceptable comfort in everyday use. The regular single-joint spring strut axle at the front was upgraded by fitting new axle stubs and bolted tiebar levers, with wheel castor increased to 16 millimetres for optimum directional stability. At the front the entire car was lowered by 25 millimetres through the use of specially modified springs, with carefully matched gas pressure dampers guaranteeing unique driving behaviour. Diameter of the anti-roll bar was increased to 19 millimetres and the pivot points were modified accordingly, now resting on the spring strut. The wheel bearings at the front came with maintenance-free double-groove ball bearings with a five-hole hub, steering roll radius increased to 14.4 millimetres and the track control arm connection on the wheel being lowered to set off the smaller roll centre.

Front track was 7 millimetres wider than on the regular models.

At the rear the suspension was lowered a moderate 15 millimetres and the spring/damper unit came with new ratings and spring forces. Diameter of the anti-roll bar was increased to 14.5 millimetres. The follower flange featured a five-hole hub and rear track was

increased by 24.5 millimetres over the production 3 Series. As a result of these modifications, the first extreme tests carried out at Nürburgring showed very soon that BMW's specialists had once again capitalised on all their “M” experience.

With many new components being tested at the time, there was obviously a need for several test models. These bore the numbers 106 – 112 and were really pushed to the limit, each test car featuring components earmarked for future use in the series version of the M3. Three of the test cars also came with an interesting dashboard variant with the rev counter turned by





BASIC DATA OF THE '86 MODEL

ENGINE (GENERAL):

Water-cooled straight-four fitted longitudinally at the front, crankshaft running in five bearings, two overhead camshafts (chain-driven), four valves per cylinder operated by cup tappets, electric cooler fan, electronic fuel injection and ignition (Bosch ML Motronic on non-catalyst engines and Bosch ML Jetronic on engines with a catalyst), unleaded premium RON 95

POWER TRANSMISSION:

Rear-wheel drive, five-speed sports gearbox (I. 3.72, II. 2.40, III. 1.77, IV. 1.26, V. 1.00, R 4.23), hydraulically operated clutch, multiple-plate differential lock (25%), final drive ratio 3.25

CHASSIS AND SUSPENSION:

Front: independent suspension on track control arms and McPherson spring struts

Rear: independent suspension on semi-trailing arms and coil springs

Front and rear: gas pressure dampers and anti-roll bars, rack-and-pinion steering with power assistance, steering transmission 16.6:1 with 3 1/4 turns from lock to lock, hydraulic twin-circuit brake system with power assistance, disc brakes front and rear (inner-vented at the front), Bosch ABS anti-lock brakes, mechanical parking brake acting on the rear wheels, 7J x 15 BBS rims, 205/55 VR 15 tyres

IGNITION:

Electronic, firing order 1-3-4-2, ignition timing not adjustable

Dynamic:	$0^{\circ} \pm 3^{\circ}$, coil
Primary resistance:	0.5- 0.85W, coil
Secondary resistance:	8250 W
Spark plug tightening torque:	15-25 Nm
Spark plugs:	Bosch X 5 DTC

EMISSION RATINGS

CO:	0.4-0.8 %,
CO ₂ :	14.5-16 %,
O ₂ :	0.1-0.5 %,
HC:	max 100 ppm
Oxygen ratio:	0.97-1.03

BMW M Power '86:

200-BHP MODEL WITHOUT CATALYTIC CONVERTER

195-BHP MODEL WITH CATALYTIC CONVERTER

FILLING QUANTITIES/SETTINGS

Engine oil incl. filter	4.4 ltr	4.4 ltr
Excluding filter	4.1 ltr	4.1 ltr
Transmission fluid	1,6 ltr	1.6 ltr
Differential fluid	1.7 ltr	1.7 ltr
Coolant	10.5 ltr	10.5 ltr
Intake valve play	0.26 - 0.35 mm (cold)	0.26 - 0.35 mm (cold)
Exhaust valve play	0.26 - 0.35 mm (cold)	0.26 - 0.35 mm (cold)

WEIGHT

Unladen	1200 kg	1200 kg
Max permissible	1600 kg	1600 kg
Max load	400 kg	400 kg
Max roof load	75 kg	75 kg

ENGINE

Cylinders/valves	4 cyl./ 16 valves	4 cyl./ 16 valves
Capacity	2302 cc	2302 cc
Max output/engine speed	147 kW / 200 BHP / 6750 RPM	143 kW / 195 BHP / 6750 RPM
Max torque	240 Nm / 4750 RPM	230 Nm / 4750 RPM
Fuel consumption + fuel grade	10.5 / premium unleaded	10.5 / premium unleaded

GEARBOX

Standard transmission ratios I/II/III	3.72 / 2.40 / 1.77	3.72 / 2.40 / 1.77
IV/V/R	1.26 / 1.00 / 4.23	1.26 / 1.00 / 4.23
Final drive ratio	: 3.25	: 3.25

PERFORMANCE

Drag coefficient	0.33 Cd	0.33 Cd
Top speed	235 KM/H (146 MPH)	230 KM/H (143 MPH)
Acceleration	0-100 KM/H IN 6.7 SEC	0-100 KM/H IN 6.9 SEC
Standing-start km in	27.2 SEC	27.6 SEC

FUEL CONSUMPTION

90 km/	5.8 LTR/100 KM	6.2 LTR/100 KM
120 km/	7.5 LTR/100 KM	7.8 LTR/100 KM
Urban	11.6 LTR/100 KM	11.8 LTR/100 KM

WHEELS

Tyres	205/55 VR 15	205/55 VR 15
Rims	7 x 15	7 x 15
Material	light alloy	light alloy

The first M3s entered series production in 1986 and the first motorsport events were planned for the following year. So although the racing version of the M3 had not yet shown its qualities on the race track, BMW Motorsport GmbH already lauded the racing success of the M3 at the Essen Motor Show. And how right they were!

1988

EUROPEAN CHAMPION, "HARD CORE" STRAIGHT FROM THE FACTORY AND THE EVOLUTION M3

Evolution, the first official Evo model (sometimes incorrectly referred to as Evo II), was presented on 17 March 1988 and was built from April – October 1988.

Back in 1987 Roberto Ravaglia wrote a brilliant chapter in the M3's story of success, winning the World Touring Car Championship for Drivers in a Group A BMW M3. BMW Motorsport GmbH promptly converted the experience gained in the process into a truly perfect model: the BMW M3 Evolution with even more power and enhanced aerodynamics. Proof of a highly successful season in motorsport and the foundation for future victories.

Through its technological leadership alone, the M3 Evolution was quite unique. Only 500 were built for the road, giving 500 drivers aware of their responsibility the opportunity to experience the dynamic competence of a world championship car themselves in everyday traffic. Unless they wanted to place the M3 Evolution in a display cabinet right next to their trophies...

The functional enhancement of the BMW M3 Evolution is the result of detailed research in the wind tunnel. The body of the car reflects all the highlights and features of well-conceived aerodynamics, flared wheel arches, side-sills and optimised spoilers providing a remarkable drag coefficient of just 0.33, despite the car's wide tyres. Optimisation of weight on the Evolution allowed the

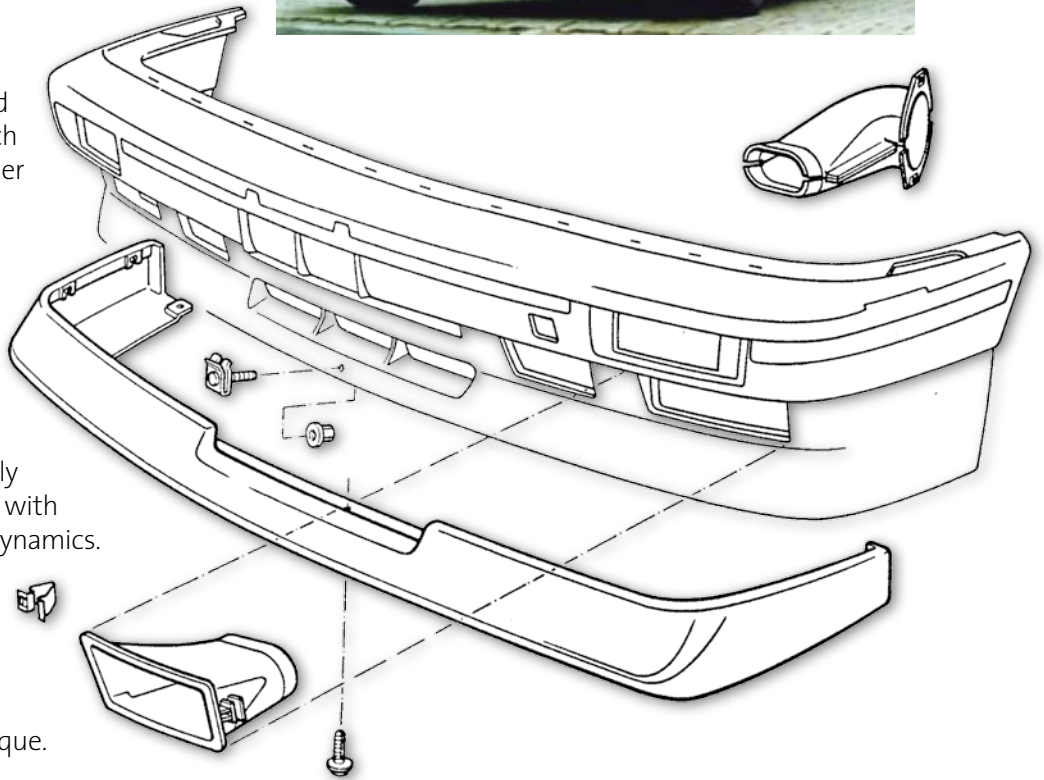

The roof opening and closing mechanism was very easy to operate also by the lady driver without lots of bars and levers or the risk of hurting your fingers. All the driver had to do was open two levers on the windscreen frame above the sun visors, everything else was automatic.



Alpine White



Mesano Red



Nagaro Silver

The customer had the choice of the same features and options as on the Saloon, with the range of non-metallic colours being limited to Misano Red and Alpine White. The metallic colours, in turn, were Diamond Black Metallic, Macao Blue Metallic and Nogaro Silver Metallic as options. The roof colours were Black or Dark Blue.

In standard trim with catalytic converter, the M3 Convertible retailed in the German market at DM 89,450.- (€ 46,108.25). Without a catalyst, the retail price was DM 88,500.- (€ 45,618.56), and all-leather upholstery in Black, Silver or Nature Beige was available at an extra cost of DM 7,000.- (€ 3,608.25).



M3 + M3 CONVERTIBLE SPECIFICATIONS 215 BHP WITH CATALYST:

WEIGHT	SALOON	CONVERTIBLE
Weight, unladen, kg	1200	1360
Max permissible, kg	1600	1720
Max load, kg	400	360
Max roofload, kg	75	
<u>ENGINE</u>		
No of cyls/valves	4/16	4/16
Capacity, cc	2302	2302
Stroke/bore, mm	84/93.4	84/93.4
Max output/engine speed kW/bhp/rpm	158/215/6750	58/215/6750
Max torque Nm/rpm	230/4600	230/4600
Mean piston speed	18.9 metres/sec	18.9 metres/sec
Battery	12 V 65 Ah	12 V 65 Ah
Alternator	1260 Watt	1260 Watt
Oil capacity, engine	5.0 litres	5.0 litres
Cooling system	9.0 litres	9.0 litres
Fuel consump + fuel grade	10.5 ltr/premium, unleaded	10.5ltr/premium, unleaded
<u>TRANSMISSION</u>		
Standard gearbox ratios I/II/III/IV/V/R	3.72/2.40/1.77 1.26/1.00/4.23	3.72/2.40/1.77 1.26/1.00/4.23
Final drive	3.25	3.25
Speed at 1000 rpm in 5th gear	34.2 km/h	34.2 km/h
Drag resistance, Cd	0.33	0.36 (with roof closed)
Top speed, km/h (mph)	241 (149)	239 (148)
Acceleration 0-100 km/h, sec	6.7	7.3
Standing-start km, sec	27.3	27.8
Acceleration 80-120 km/h with sports gearbox in 4th gear, sec	7.8	8.4
<u>FUEL CONSUMPTION</u>		
90 km/h, ltr/100 km	6.2	6.2
120 km/h, ltr/100 km	7.8	7.8
Urban, ltr/100 km	12.4	12.4
Average, ltr/100 km	8.8	8.8
<u>WHEELS</u>		
Tyre dimensions	205/55 ZR15	205/55 ZR15
Wheel dimensions	7Jx15	7Jx15
Material	Light alloy	Light alloy

1990: M3 SPORT EVOLUTION



According to Group A regulations for production-based touring cars back then, modification of the engine, chassis and body required a production volume of at least 500 units. And since BMW wished to remain in motorsport with the very successful M3, it was only logical to upgrade the car to an even higher standard. The result was the M3 Sport Evolution built in a production run of exactly 600 units.

The driving force behind the car, the power unit as the heart of the M3, was enlarged in the M3 Sport Evolution from 2.3 litres by 7 per cent to 2.5 litres, with output increasing 11 per cent to 175kW/238 bhp. Bore was up from 94 millimetres on the 2.3-litre to 95.5 millimetres, with the block otherwise remaining unchanged. Stroke was increased from 84 to 87 millimetres, giving the engine overall capacity of 2492.7 cc. In comparison with the 2.3-litre, the pistons and crankshaft were optimised for minimum weight and the pistons were cooled by a particularly sophisticated system using splash oil from the wet sump. The valves, finally, were filled with sodium in order to dissipate heat from the valve plates into the valve shafts.



The ECU Electronic Control Unit developed by BMW Motorsport in 1989 for optimum control of the engine also served in the Sport Evo to mastermind the oxygen sensor and was further enhanced to provide even greater memory capacity.

Through its output alone, this 2.5-litre normal-aspiration catalyst engine was the cutting edge in worldwide automotive technology. Other manufacturers sought to achieve the same kind of power by boosting the engine with the help of a turbocharger or compressor.

BMW's unrivalled solution, however, had always been normal-aspiration power of the highest standard. And this engine offered qualities nobody had seen before. A three-way metal-based catalytic converter with relatively low exhaust gas counterpressure and with the same cleaning capacity, but without the slightest loss of power.

Maximum torque was now 240 Nm at 4750 rpm, acceleration to 100 km/h came in just 6.5 seconds, and top speed of 238 km/h or almost 148 mph fulfilled all the wishes of even the most ambitious driver.

Without doubt, the absolute highlights were the adjustable spoilers front and rear. This was racing at its best!



THE BEAUTY AND THE BEAST

ALPINA IN THE DTM GERMAN TOURING MASTERS

Towards the end of 1986, Burkard Bovensiepen decided to return to motorsport after a break of ten years, taking up the concept of the M3 touring car so successful on the track bath in modular form and as a completely built-up racing car.

ALPINA was one of the first to order a modular racing car kit bearing chassis number M3-35. The result was the ALPINA MICHELIN M3 making its appearance in the DTM and World Championship scene in 1987 in that special green colour so typical of ALPINA as one of the



most beautiful racing cars on the track.

The first race for the World Touring Car Championship was in Monza on 22 March 1987, with ALPINA presenting their beautiful car for the first time. Starter number 52 was driven by Andy Bovensiepen, Burkhard Bovensiepen's son, and Eric van de Poele, who finished as the best private team in the very first race of a Group A M3 in Monza in eighth position overall. Indeed, BMW M3 drivers finished 1st – 6th in the first race in Monza, as well as in 8th position, but were subsequently taken off the list after the race due to the sheet metal on the roof allegedly being too thin.

ALPINA raced only from time to time in the World Touring Car Championship (Monza, Nürburgring, and Brno) and in the European Championship (Osterreich Ring), since their focus was on the DTM. Up to the sixth race at Norisring, ALPINA entered only one team car in the DTM, with Andy Bovensiepen driving starter number 33. Starting at Nürburgring, ALPINA raced an M3 with chassis number M3-48, with drivers Fabien Giroix in No 51 and Ellen Lohr in starter number 52, since Andy Bovensiepen, due to an "unfortunate position of the gas pedal in top gear and at top engine speed" on the German Autobahn had been required to hand in his driver's licence for a short while to the authorities in the Parc Fermé.



Fabien Giroix made his debut at Nürburgring most successfully, finishing second in his very first race in the car and scoring ALPINA's first racing win in Diepholz.

The beautiful paintwork in green with its harmonising blue contrast fascinated not only the crowd along the track, but also the drivers, teams and other enthusiasts in the paddocks.

Perfection was ALPINA's name of the game from A – Z. Not only the racing transporter was finished in the same design, but also ALPINA's motorhome. This was and is corporate identity all the way.



SPECIAL TUNERS, SPECIAL MODELS

 The logo for AC Schnitzer, featuring the letters 'AC' in a large, stylized, metallic font above the word 'SCHNITZER' in a similar, bold, metallic font.

 The logo for MK-Motorsport, featuring the letters 'MK' in a large, stylized, metallic font above the word 'Motorsport' in a similar, bold, metallic font.

 The logo for Hamann, featuring a stylized arrow icon to the left of the text 'AUTOMOBILE TECHNIK + DESIGN' above the word 'HAMANN' in a bold, metallic font.

 The logo for LSTEC, featuring the letters 'LSTEC' in a large, stylized, metallic font.

Out there right from the start!

Fun is when you can never get enough! So with this in mind Motorsport GmbH had a great group of enthusiasts who really could never have enough fun – above all, they could never enjoy too many wins on the track, which is precisely why they built the M3 as the perfect starting point for motorsport at the same time setting the benchmark in the sports saloon market.

A number of outstanding tuners naturally interpreted “fun” as the process of increasing power and performance to the utmost. And again, the M3 offered an excellent starting point for this purpose, too. While benefiting from excellent balance right from the start, the M3 still gave BMW tuners the opportunity to add a few more features.

Even in „basic“ trim, the series models offered output per litre in the non-catalyst version of no less than 87 bhp. And with the best Group A M3s developing some 315 bhp in 1988, they were able to beat the regular production models by 115 bhp on this count alone. So obviously, the tuners out there in the market quickly started focusing on the 200-bhp mark.



THE ART CARS

BY KEN DONE AND MICHAEL JAGAMARA NELSON

BMW has been involved in culture for more than 30 years – both regionally at BMW’s various and on an international level. Concentrating on innovative technology and art, and promoting an artistic challenge in today’s world of technical change, social upheaval and economic progress is a significant activity by the BMW Group operating globally and looking for world-wide success.

It is therefore only natural for the BMW Group to focus on the latest trends in society and act as the driving force behind new developments. Hence, BMW has always seen technical and artistic challenges as an essential part of today’s culture. Technology shapes our culture just as our technical world requires cultural input.

BMW has always sought to highlight this close relationship, for example through the BMW Art Car Collection. Ever since 1975 artists of absolute world fame have turned BMW cars into works of art on four wheels. Everything started in 1975 with Alexander Calder, Frank Stella coming next in 1976, Roy Lichtenstein in 1977, Andy Warhol in 1979, Ernst Fuchs in 1982, Robert Rauschenberg in 1986, and Ken Done as well as Michael Jagamara Nelson in 1989 with the E30 M3.

Ken **D**ONE, who transformed a 1989 Group A M3 into his Art Car, was born in Sydney in 1940. He left school at the young age of 14 to study art at the National Art School in Sydney. After working as a commercial graphic artist in Sydney, London, and New York for 20 years, Ken ultimately gave up his job to have more time for painting.

In 1980 he had his first exhibition in Sydney and, apart from being recognised as a leading graphic designer, was lauded for the first time as one of the most outstanding painters in Australia.

In 1988 he was requested to create the exterior design of the Australian and United Nations pavilions at the EXPO World Fair.

A very talented and hard-working man, Ken very often works on several objects at the same time, his pictures reflecting the typical face of Australia with its landscapes, animal world, beaches and gardens in striking colours and strokes of the brush.

Ken Done’s objects are to be admired in museums the world over.



SCHNITZER

MOTORSPORT

SCHNITZER – THE THREE KINGS



Writing a story about the Schnitzer M Team is like writing a complete book on motorsport. Because their history and ties with BMW go back so far and are so significant.

This connection quite unprecedented in the world of sports started far more than a quarter of a century ago: It was back in 1963 that Schnitzer first came into contact with a racing car. The place where it all began was the small German town of Freilassing,

some 20 kilometres from Salzburg, where Schnitzer's parents had a filling station and a driving school. Together, Herbert and Josef Schnitzer built their first racing car at their parent's workshop – which, back then, did not come in the white-and-blue colours of Munich, but rather in red, bearing the name Fiat Abarth. Just a few months later and after a few races, the two brothers established their first contact with Munich destined to last for decades in the guise of their first BMW, a BMW 700.

1990 DTM

St No	DRIVER	TEAM	OVERALL POINTS	
3	Cecotto	Schnitzer	2nd	177
8	Soper	Bigazzi	4th	152
9	Winkelhock	Bigazzi	6th	119
10	Laffite	Bigazzi	7th	107
11	Heger	Linder	8th	98
2	Giroix	Schnitzer	9th	94
19	Hahne	Zakspeed	12th	68
29	Pirro	Schnitzer	15th	36
1	Ravaglia	Schnitzer	17th	32
31	Schmickler	MM	19th	22
18	Qeuster	Zakspeed	20th	20
12	Nissen	Linder/ Valier/Auto	23rd	8
28	König	Maass	24th	7
23	Manthey	Isert	26th	4
30	Murmann	MM	28th	3
24	v.Bayern	Isert	30th	2
22	Grohs	Valier	31st	1
34	v.d.Poele	Schnitzer	32nd	1

Entering the 1990 season, BMW planned a mass appearance of works cars, with more than 20 genuine works cars on the grid for the DTM! Not only the cars' technical features developed incredibly during this period, but also the tyres used in racing, which even had an influence on the round robin of drivers. Steve Soper, who did not lose his chances for the title until



The crowd of 70,000 excited fans cheered on Roberto to victory, making even this experienced driver shed a tear at the end: the M3 had done its duty and had reached the end of the road. And in the second race in Hockenheim the M3 finished first through to fourth – what a farewell performance! The only man missing in Hockenheim was Roberto's Team Manager Charly Lamm. And where was he? Getting married! Okay, that was also a kind of victory, the only difference being that this time Ms Lamm had won over Mr Lamm!

Now nobody knew what was coming next. One single E36 M3 was built and tested according to DTM regulations. But to achieve an optimum balance of weight, the six-cylinder had to be moved back together with the bulkhead, which again meant that BMW actually had to leave the racing scene. Why? Because the immensely powerful lobby from Stuttgart rejected such a modification and planned new rules for the 1993 DTM no longer in compliance with the motorsport philosophy in Munich.

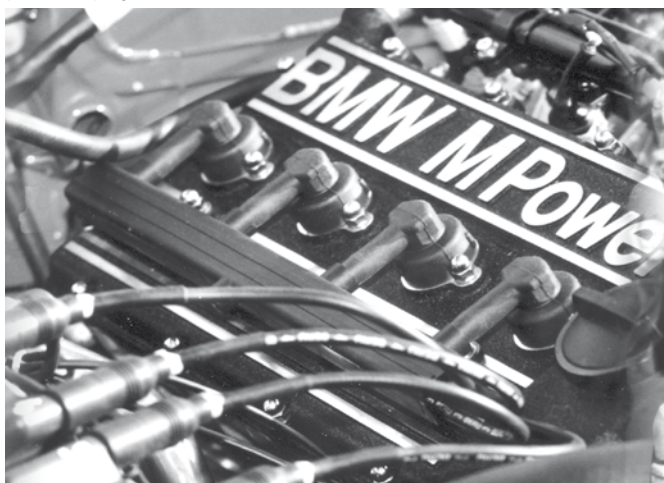

MY STORY

Writing this book was such a wonderful experience that I never wanted to stop. But at some point even I reached the deadline.

What will always remain in my memory is the great friendship I enjoy – and have re-lived over so many years – with those wonderful drivers, team managers and other participants in motor racing way back then.

When I handed over my manuscript to my layout designer and my work was “finished” at least in theory, I also, as coincidence will have it, experienced the happiest moment throughout the entire project: An E30 M3 in Alpine White II was up for sale – a car you wouldn’t think even existed: built in October 1990, almost fully loaded, and with an original 31,892 kilometres on the clock – which, for our American friends, is just 19,773 miles.



go to the “right guy”.

Now I am the proud owner of AE 42137 and I naturally drive this wonderful car only on special occasions.

The last model ever built, incidentally, was AE 42418, meaning that only 281 M’s came after mine.

And I bet that my M will outlive them all ...!

In my days as an active journalist permanently accredited in motorsport I enjoyed the greatest time I have ever experienced in racing. Now this book takes us all through this wonderful period once again. Together with my friends, the racing drivers and team managers back in the old days, I experienced wonderful hours we will never forget.

At the time I had been looking for an M3 of the kind I had already owned in 1990 for ten long years. And obviously, it had to be exactly the same car! In that characteristic Alpine White M colour, and naturally as good as new. In September 2005 my dream came true, and I naturally bought the car without having to think twice. Günther Müller, a pilot in the German Air Force and therefore a man who spends more time in the air than on the ground, wanted to sell his M3 since he did not have enough time to drive his wonderful car even a few metres each month. So it was one man, one word, a perfect deal. And Günther wanted me specifically to buy his M3, since he wanted the car to

I now wish all readers of this book the same great enjoyment I have experienced myself. And I wish those lucky few who still have an M a great time taking care of their wonderful car just like ...

Yours
Peter S.

That was in 2005....

Marc Hessel ft. twenty years BMW M3

